

Customer: ALPS EUROPE DISTRIBUTION

No. SSV2008-5221

Date: Nov. 17, 2008

Attention:

Your ref. No.:

Your Part No.: RS451121400A

## SPECIFICATIONS

ALPS;

MODEL: RS451121400A  
( 10 kB X2 )

Spec. No.:

Sample No.: F 6 9 3 5 7 1 7 M

### RECEIPT STATUS

RECEIVED

By Date

Signature

Name

Title

**ALPS**<sup>®</sup>  
ALPS ELECTRIC CO., LTD.

DSG'D

*K. Abe*

C-B

APP'D

*S. Sato*

ENG. DEPT. DIVISION

Sales

Head Office  
1-7, Yukigaya-otsuka-cho, Ota-ku, Tokyo, 145-8501 Japan  
Phone,+81(3)3726-1211

B6523

Q1003#03A (EA)

# S P E C I F I C A T I O N S

1. THIS SPECIFICATIONS APPLY TO RS451121400A POTENTIOMETER.

2. CONTENTS OF THIS SPECIFICATIONS.

F6935717M

4S0001-200, 4S0001-201

S4528G402A

3. MARKING

• MARKING ON ALL UNITS

DATE CODE, RESIST. VALUE, TAPER

• CAUTION

Regardless of the suggested applications of these products being introduced in the specifications, when using them for equipment and devices requiring a high degree of safety, respective manufacturers will please preserve safety of the planned equipment and devices by providing necessary protective circuits and redundancy circuits and reconfirm if safety is being duly preserved.

This product has been designed and manufactured for general electronic devices, visual devices, home electronics, information devices and communication devices. In case this product is used for more sophisticated equipment requiring higher safety and reliability, such as life support system, space & aviation devices, disaster prevention & security system, please make verification of conformity or check on us for the details.



It is prohibited to use this product for flight control purposes in avionics applications.

Although we are exerting our best efforts to maintain the quality of these products, we cannot guarantee that they will never cause short circuiting and open circuitry. Therefore, when designing an equipment or device with which the priority is given to the safety, you will please carefully study the influences to the whole equipment of a single function failure of Potentiometers and Encoders in advance to make out a fail-safe design providing.

<Storage>

- 1) Store the products as delivered, at a normal temperature and humidity, without direct sunshine and corrosive gas ambient.  
Use them at an earliest possible timing, not later than six months upon receipt.
- 2) After breaking the seal, keep the products in a plastic bag to shut out ambient air, store them in the same environment as above, and use them up as soon as possible.
- 3) Do not stack too many cartons.

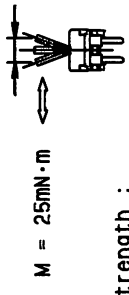
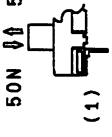
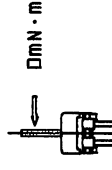
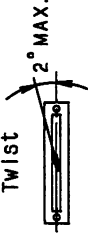
CLASS No.	TITLE						
	STANDARD TYPE POTENTIOMETER (SLIDE)						
<p><b>ELECTRICAL</b></p> <ol style="list-style-type: none"> <li>Overall resistance : <math>10k\Omega \pm 20\%</math></li> <li>Minimum resistance : Across term. 1-2 300 max. , Across term. 2-3 500 max.</li> <li>Taper : B Taper</li> <li>Rated power : 0.125Watts</li> <li>Rated voltage : Rated voltage = <math>\sqrt{P \cdot R}</math> (V)  P : rated power (W)  R : nominal overall resistance (<math>\Omega</math>)</li> </ol> <p>When the rated voltage exceeds the maximum operating voltage the maximum operating voltage shall be the rated voltage.</p> <p>Maximum operating voltage : A.C. 200 V , D.C. 10 V</p> <ol style="list-style-type: none"> <li>Dielectric test : Units shall be designed to withstand 300 volts A.C. 50 Hz R.M.S. between resistance elements and case for a period of one minute without damage or arcing.</li> <li>Insulation resistance : Greater than 100 megohms between resistance elements and case when tested by a 250 volts D.C. insulation resistance meter.</li> <li>Sliding life test : 15,000 cycles.</li> <li>Tracking error : 2dB at the point 50% travel.</li> </ol> <p>*Lever shall be operable with speed of 20 mm per sec. without noise by static electricity.</p>							
 <b>ALPS ELECTRIC CO., LTD.</b>							
SYMB	DATE	APPD	CHKD	DSGD	TITLE	SPECIFICATIONS	DOCUMENT NO.
							F 6935717M (1/3)

CLASS No.	TITLE						
	STANDARD TYPE POTENTIOMETER (SLIDE)						
<p><b>MECHANICAL</b></p> <ol style="list-style-type: none"> <li>Travel : Specified in particular Figure.</li> <li>Operating force : 0.3N - 2.5N ( Note 1 )</li> <li>Starting force : Operating force + 1N max. ( Note 1 )  ( Note 1 ) Measuring temperature : 5 C - 35 C  Measuring point : 5 mm from lever end .  Sliding speed : 20 mm per sec.</li> <li>Stop strength :  50N at a position 5 mm from mounting surface.</li> <li>Lever lateral play :  When an alternating bending moment of 25mN·m is applied perpendicular to the direction of lever travel , the both sides movement of the lever shall be less than 2(2L/20)mm.  L : Lever length on the measurement point from mtg. surface.  ( Note 2 ) Exempt warping of insulated lever.</li> </ol> <div style="text-align: center;">  <p>M = 25mN·m      Lever lateral play</p> </div> <ol style="list-style-type: none"> <li>Lever strength :  (1) To be resistant with 50N static force of pull or push applied to lever in thrust direction for 10 seconds without damage.  (2) To be resistant with following static force applied to lever in vertical direction to lever driving for 10 seconds without damage.  ① No damage with an application of 0.2N·m  : In case of pot., mounted to chassis with screws.  ② No damage with an application of 50mN·m  : In case of pot., mounted to P.C.B. only with terminals.</li> </ol> <div style="text-align: center;">  <p>50N <math>\downarrow</math> 50N      (1)</p>  <p>50mN·m      (2)</p> </div> <ol style="list-style-type: none"> <li>Lever inclination and twist :   <p>Twist      2° MAX.</p>  <p>Inclination      2° MAX.</p> </li> <li>Resistance to soldering heat : 3 sec. max. at 350°C</li> </ol>							
 <b>ALPS ELECTRIC CO., LTD.</b>							
SYMB	DATE	APPD	CHKD	DSGD	TITLE	SPECIFICATIONS	DOCUMENT NO.
							F 6935717M (2/3)



ご使用上の注意  
PRECAUTION IN USE

1. 偏心ツマミをご使用になる場合  
 レハ<sup>レ</sup>の中心より離れたところを作用点としてご使用になる場合、可能な限り  
 下図A寸法を短くしてご使用下さい。  
 If it will be used the operating point away  
 from the center line of the lever, it should  
 be shorter as possible.
2. レハ<sup>レ</sup>長さについて  
 レハ<sup>レ</sup>長さについては、ツマミを含めて、下図B面より極力短いものを  
 ご使用願います。レハ<sup>レ</sup>長さについては、作用点までの距離が短いほど  
 しゅう動感が良好となり、長いほど好ましくない感触になります。  
 About the length of lever  
 If conditions permit, it is advisable to use  
 the shortest possible lever.  
 The longer the length up to operating point,  
 the more unfavorable slide feeling  
 will be given.

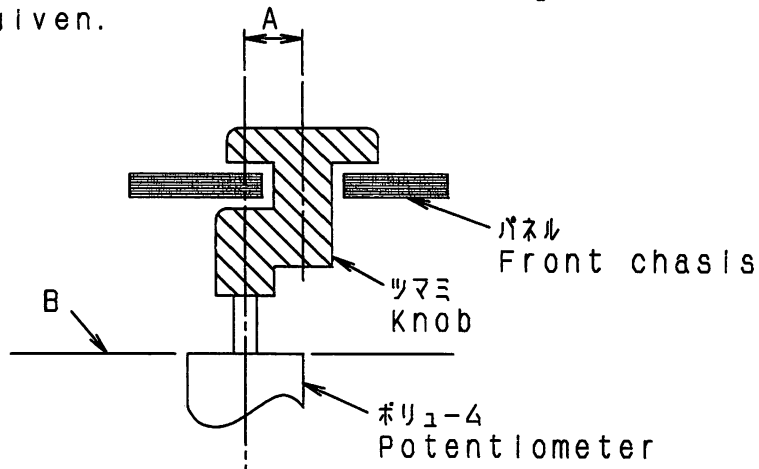

3. レハ<sup>レ</sup>の駆動に関しては上記内容を考慮の上、セット実装を行い  
 あらかじめ異常のないことをご確認願います。  
 Regarding the operation of the lever, please  
 consider the above mentioned, and make  
 sure nothing is wrong with the operation  
 under installing in your appliance  
 that you plan to use our products actually.
4. ツマミ挿入及びレハ<sup>レ</sup>操作は、ホ<sup>レ</sup>リウムマウント基板に  
 ソリ(曲がり)のない状態で行って下さい。  
 Knob assembly on the lever and functioning  
 the lever to be performed under the condition  
 of P.C.B. without warp.
5. 電圧調整形回路において出力側のインピーダンスが低い場合には抵抗体と摺動子間の  
 接触抵抗の影響を受けることがありますのでインピーダンスを公称全抵抗値の100倍  
 以上に設定願います。  
 There is a possibility that might be affected by  
 contact resistance of resistive element and wiper  
 in case of low impedance of output side in voltage  
 regulation circuit. for this reason, we require that  
 you adjust to impedance of output side more than 100  
 times of total resistance.

					<b>ALPS ELECTRIC CO., LTD.</b>					
					APPD.	CHKD.	DSGD.	TITLE		
					選・設計試作 '07-4-5 池之上	選・設計試作 '07-4-5 大矢	選・設計試作 '07-4-5 玉田	スライト <sup>レ</sup> ホ <sup>レ</sup> リウム仕様書 SPECIFICATIONS		
ORIGINAL	1991-07-03	Y·Y	K·N	S·A				DOCUMENT NO.		
SYMB	DATE	APPD	CHKD	DSGD				450001-200		

F6935717M

はんだ付け条件

FOLLOW THE NEXT CONDITIONS FOR SOLDERING

1. はんだ SOLDER

JIS Z 3282に規定のA30C5はんだを使用  
A30C5 solder specified in JIS Z 3282.

2. 使用基板 BOARD IN USE

両面スルーホール基板又は、片面銅張積層板 板厚  $t=1.6\text{mm}$   
Double-faces through-hole board or single-face  
copper laid laminate board.  
Plate thickness ( $t$ )= $1.6\text{mm}$

3. 自動はんだ<DIP条件>

- (1)レバ位置 センター付近に設定願います。
- (2)フラックス比重  $0.83\pm 0.01$  (発泡式)
- (3)フラックス高さ フリント基板の板厚の半分の位置にフラックスの上面が接するレベル(図1)  
又、ホリウム挿入面への流れ込みのないこと。(フラックス上がり、飛散に注意)
- (4)プリヒート温度  $100^{\circ}\text{C}$  max. 時間1分以内。(フリント基板のホリウム挿入側の温度)
- (5)はんだ温度  $260^{\circ}\text{C}$  max. 時間5秒以内. はんだ回数は1回までとする。

IN THE CASE OF DIP SOLDERING

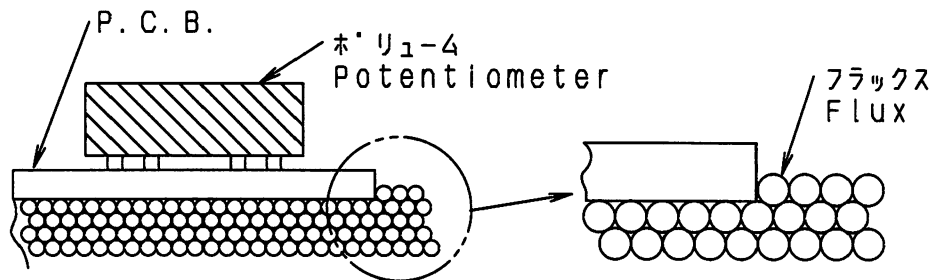

- (1)State of potentiometer  
Position a lever in the vicinity of center.
- (2)Specific Gravity of Flux  
 $0.83\pm 0.01$  (foaming type)
- (3)Height of Flux face  
A level of the upper face of flux for reaching  
the position at a half of the plate thickness  
of printed board. (Fig. 1)  
Further, no flow of flux invading on the  
surface of printed board on the side of  
installing potentiometer is allowed.
- (4)Preheat condition  
 $100^{\circ}\text{C}$  max., within 1 minute  
(Temperature on the side of installing printed  
board is designated.)
- (5)Soldering condition  
Solder temperature:  $260^{\circ}\text{C}$  max.  
Soldering period ; within 5 seconds  
Time of soldering ; only one time is permitted



(Fig. 1)

4. 手はんだ IN THE CASE OF MANUAL SOLDERING

はんだ温度  $350^{\circ}\text{C}$  max. 時間3秒以内 はんだ回数は1回までとする。  
Solder temperature ;  $350^{\circ}\text{C}$  max.  
Soldering period ; within 3 seconds  
Time of soldering ; only one time is permitted

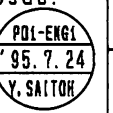
					<b>ALPS ELECTRIC CO., LTD.</b>			
					APPD.	CHKD.	DSGD.	TITLE
								スライトホリウム仕様書 SPECIFICATIONS 1/2
ORIGINAL	'91-9-3	Y·Y	S·A	S·S				DOCUMENT NO.
SYMB	DATE	APPD	CHKD	DSGD				450001-201

F6935717M

5. 注意事項

- (1) はんだ付けの際に、端子にストレスを加えないで下さい。例えば、端子に熱を加えたまま製品を動かしますと、かしめ力<sup>\*</sup>及び電気的特性が劣化する恐れがあります。
- (2) 両面スルーホール基板を使用する場合は、ホ<sup>\*</sup>リウム挿入側の端子取付穴に、はんだランド<sup>\*</sup>がないようにご配慮願います。ホ<sup>\*</sup>リウム挿入側での配線が必要な場合は端子取付穴からの直接取り出しを避けスルーホール配線用の穴を設けるなどのご配慮をお願いします。
- (3) ホ<sup>\*</sup>リウム挿入側へのはんだ上がりは、はんだ熱による端子接触不良の発生原因となりますので(図2)を参照願います。
- (4) リード<sup>\*</sup>配線の場合、ホ<sup>\*</sup>リウム本体と、はんだ付け部の距離を1mm以上開けてはんだ付け願います。(図3)
- (5) はんだ付けによるホ<sup>\*</sup>リウムへの影響は、フ<sup>\*</sup>リント基板の大きさ、ホ<sup>\*</sup>リウムの取付け位置、はんだ槽の大きさ、等により異なりますのであらかじめ実使用状態で実施し、異常のないことを確認の上、はんだ付けて下さい。

MATTERS TO BE NOTED

- (1) Do not add any stress on terminals in the case of soldering. For instance, forced movement of potentiometer with terminals being heated may probably deteriorate the electric features due to generation of looseness in connection between resistant board and terminals.
- (2) Avoid use of double-faces through-hole board as much as possible. If it is necessary to use it, Do not apply through-hole plating to a hole in which a potentiometer is inserted, and install a land to which terminals are soldered only on a face oppsite to the face on the side of installing potentiometer.
- (3) Use caution to soldering process so as to prevent solder from rising up to the surface of printed board on the side of installing potentiometer, because defective contact may take place in terminal connecting part due to soldering heat .(Fig. 2)
- (4) In the case of lead wiring, solder it so that a gap of 1 mm or more may be reserved between the potentiometer body and soldering part.(Fig. 3)
- (5) The grade of influence of soldering exerted on the potentiometer depends upon the size of a printed board, installing position of the potentiometer, and the size of a solder bath etc. Therefore, make sure, in advance, of no abnormal state under the conditions of soldering to be carried our at present.

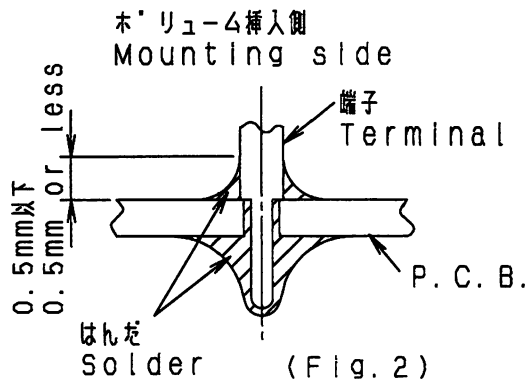

(Fig. 2)

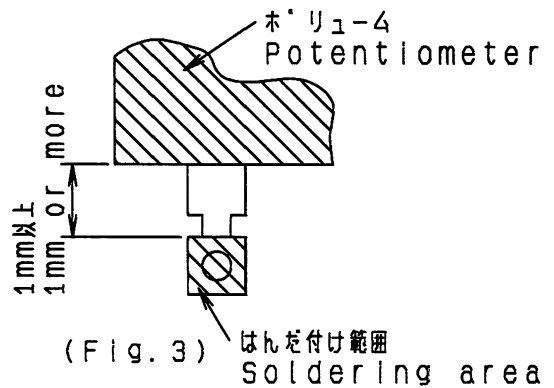

(Fig. 3)

					<b>ALPS ALPS ELECTRIC CO., LTD.</b>					
					APPD.	CHKD.	DSGD.	TITLE スライド <sup>*</sup> ホ <sup>*</sup> リウム仕様書 SPECIFICATIONS 2/2		
					PDI-ENGL '95.7.24 YOSIOKA	PDI-ENGL '95.7.24 KIMURA	PDI-ENGL '95.7.24 Y. SAITOH	DOCUMENT NO. 450001-201		
ORIGINAL	'91-9-3	Y·Y	S·A	S·S						
SYMB	DATE	APPD	CHKD	DSGD						

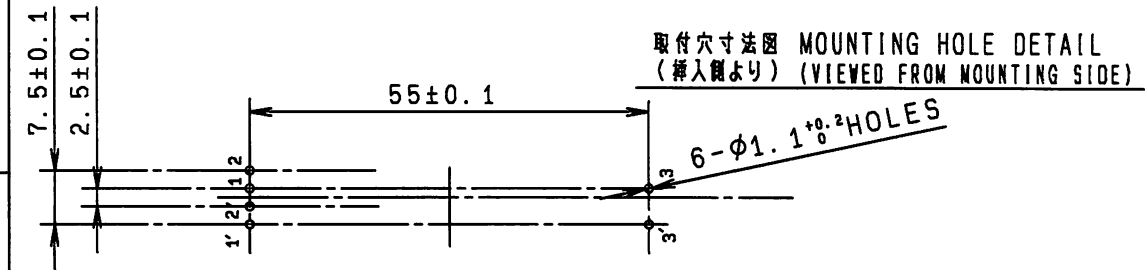
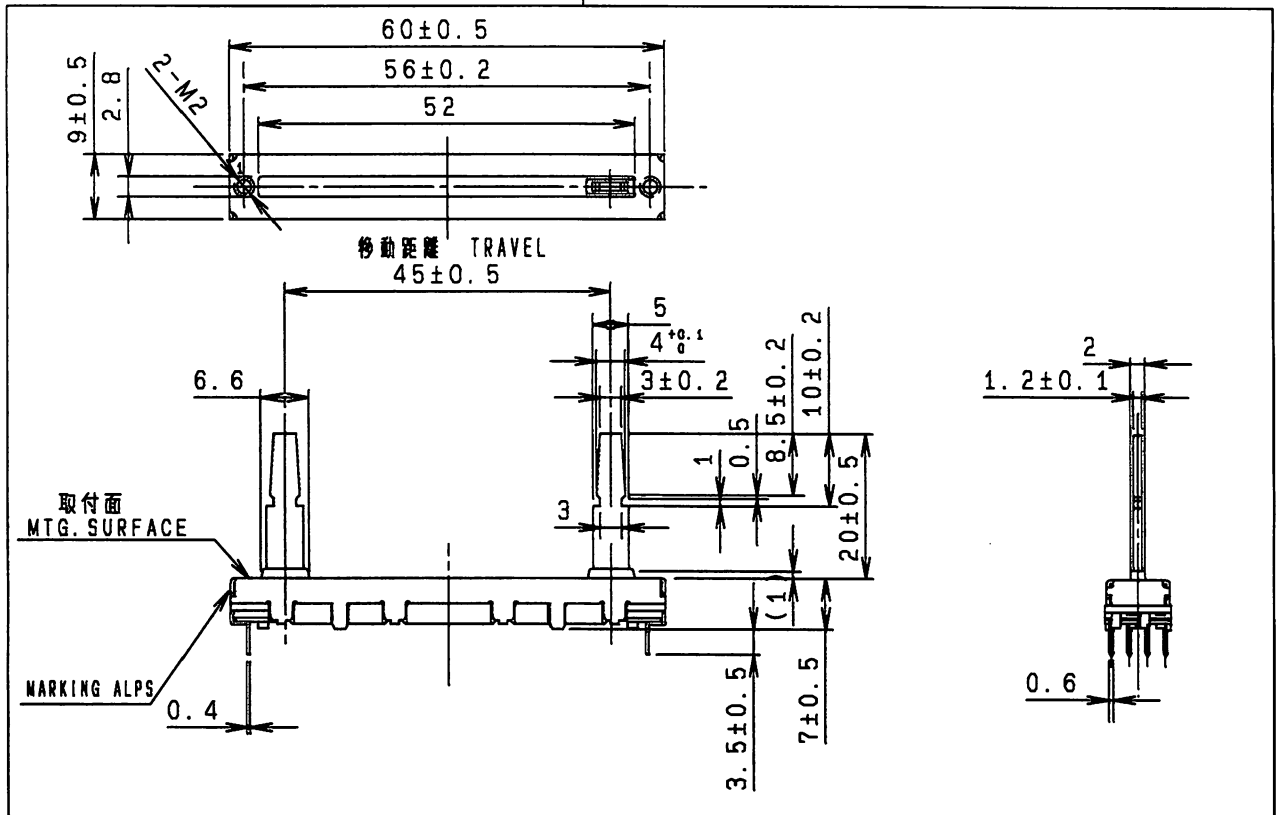

- NOTES
1. MOUNTING SCREW THREAD LENGTH IS CHASSIS THICKNESS +2mmMAX.  
取付用ネジの首下長さは、シャーシ板厚 +2mm以下とする。
  2. TOP SIDE OF KNOB SHALL BE MOUNTED TO LEVER WITHIN 30mm LENGTH FROM LEVER MTG. SURFACE.  
取付面からツマミ先端まで 30mm以内でご使用願います。

製品質量 5.4 g  
WEIGHT

指定なき部分の許容差 TOLERANCES UNLESS OTHERWISE SPEC	
$L \leq 10$	±0.3
$10 < L < 100$	±0.5
$100 \leq L$	±0.8
角度 ANGULAR DIMENSION	±5°

PART NO.	NAME	MATERIAL NAME / CODE	FINISH	
<b>ALPS ELECTRIC CO., LTD.</b>				
		DSGD. セツケイ K. SATOU '93-06-16	SCALE 1:1	NO.F6935717M S4528G402A
		CHKD. S. ABE '93-06-16		TITLE SLIDE POTENTIOMETER DUAL UNIT
		APPD. Y. YOSHIOKA '93-06-16	UNIT III III	DOCUMENT NO. 4111
SYMB	DATE	APPD	CHKD	DSGD